



2025 Community Funding Project Title: Scene Response & Development

Total Funding Request: \$1,192,322.00

Requesting Agency: Siskiyou County Sheriff's Office

Agency Location: 305 Butte Street, Yreka CA 96097

Agency Website: <https://www.co.siskiyou.ca.us/sheriff>

Agency Contact: Courtney K. Greenley, Administrative Services Manager

Agency Contact Email: cgreenley@co.siskiyou.ca.us

Agency Contact Desk Phone: (530) 842-8326

Item #1: RapidHIT DNA Machine

- 1) **Project Information:** RapidHIT ID Machine
- 2) **Primary Location:** 305 Butte Street, Yreka CA 96097
- 3) **Summary:** The RAPIDHIT ID instrument analyzes DNA samples in 90 minutes for rapid comparison. This can be conducted within a lab environment or at a scene to include natural disasters like wildfires. Rapid DNA has many uses ranging from unknown decedent identification to crime scene lead generation.
- 4) **Project Funding and Costs:**
 - a. **Total Project Cost:** \$285,947.00
 - b. **Total Item Request:** \$291,666.00
 - i. (assumed 2% increase from time of original quote)
 - c. **If request is granted, will additional funding be necessary to complete the project?** Not the we can anticipate at this time.
 - i. **What is the status on any current attempts to acquire additional funds?** None.
 - ii. **Can the project be started without these additional funds?** No.
 - d. **Has the project received funding from other sources?** No
 - i. **This should include Federal, State, local, non-profit, corporate, or any other entities which have provided funding.** No
 - e. **Why is this project a priority for California's 1st Congressional District?** This technology would aid in bringing closure and justice to the community members of the underfunded rural communities within the district. Butte County is the only county within the district to have a Rapid DNA instrument. They currently have an ANDE Rapid DNA instrument which is a competitor to RAPIDHIT ID. The field is moving in the RAPIDHIT ID direction as ANDE has had ethical issues, lost sales representative backing, and has been blacklisted for use within other states. Government agencies including the US Armed Forces have

transitioned to the use of RAPIDHIT ID over ANDE in a continued trend showing the superiority of the RAPIDHIT ID instrument. Without a trusted Rapid DNA instrument, the entire congressional district’s only options for DNA testing is through Bureau of Forensic Services (BFS) laboratories or private forensic labs throughout the country. BFS labs are very selective on the cases and number of samples they will process as backlogs are high and the turnaround time for those cases are lengthy. Private laboratories offer faster turnaround times, but each sample comes with a high price which is taxing on budgets and still longer turnaround times than could be accomplished using the RAPIDHIT ID. The Siskiyou County Sheriff’s Office would be happy to provide Rapid DNA services to municipalities in need within our county as well as offering other counties and jurisdictions within the district to enter a MOU for the services as well. The project should be a priority for California’s 1st congressional district to serve the community members identifying deceased loved ones, responding to natural disasters, and providing investigative leads to identify suspects, keeping the community safer.

- f. **Why is this project a good use of taxpayer funds?** This project is a good use of taxpayer funds as it directly impacts the taxpayer’s safety while also providing closure when it is needed the most. Taxpayers look to law enforcement for answers when loved ones are presumed deceased or missing and this project aids in the speedy identification to give those answers. Taxpayers also assume law enforcement takes every step necessary to keep them safe. Necessary steps to investigate cases means testing items of evidence to identify suspects. The lack of ability to submit evidence in all criminal offenses, the sample limitation on testing cases that are approved, the extended turnaround time, and the extravagant cost of private laboratory testing are all factors that work against our promise to the community members we serve.
- g. **Are you requesting this project from another Representative, or either of California’s Senators?** No
- h. **Do you have documentation showing community support for this project?** Yes, attached.
 - i. **Letters of support from elected officials.** Yes, three are attached.
 - ii. **Articles in a local newspaper, including editorial boards.** No.
 - iii. **Federal, State, or local plans identifying the project as needed – such as an infrastructure or community development plan.** No.
 - iv. **Local resolutions passed in support of the project.** No.

5) Supporting Documentation:

Vendor Quote: Thermo Fischer

2024 RapidHIT ID Proposal
 RapidHIT ID INSTRUMENT AND SOFTWARE*
 Customer: Siskiyou County

Item	Part Number	Description	Quantity	2024 Proposal Price	Total Extended Price
1	A41810	Applied Biosystems™ RapidHIT™ ID System*	1	\$189,500.00	\$189,500.00
2	A59183	Applied Biosystems™ RapidLINK™ Software v2.0 License*	1	\$12,500.00	\$12,500.00
3	A48503	RapidLINK™ Laptop System*	1	\$2,985.00	\$2,985.00
4	A59805	RapidLINK™ Matching Suite v1.0	1	\$12,600.00	\$12,600.00
5	ZG11SCRHID	Applied Biosystems™ Assurance for RHID	1	\$17,829.00	\$17,829.00
6	ZGLPSCRHID	Applied Biosystems™ 24/7/365 Rapid Priority Support	1	\$3,216.00	\$3,216.00
7	A53084	Applied Biosystems™ RapidHIT™ ID Primary Cartridge GlobalFiler™ Express 150 Kit	1	\$10,120.00	\$10,120.00
8	A41831	Applied Biosystems™ RapidHIT™ ID ACE GlobalFiler™ Express 50 Sample Kit	1	\$7,250.00	\$7,250.00
9	A54338	Applied Biosystems™ RapidINTEL™ Plus Cartridge Kit, 50 Sample Kit	1	\$7,790.00	\$7,790.00
10	A54344	RAPIDINTEL PLUS LADDER 5 CART. EA	1	\$1,330.00	\$1,330.00
11	A54342	RAPIDINTEL PLUS POSITIVE CART EA	1	\$260.00	\$260.00

RAPIDHIT COST BREAKDOWN

Quoted Cost	\$ 265,380.00
Tax @ 7.75%	\$ 20,566.95
Grand Total	\$ 285,947.00
2% Vendor Increase	\$ 5,307.60
Add'l Tax	\$ 411.34
Requested Amount:	\$ 291,666.00

Item #2: Nomad Mobile Command Vehicle

- 1) **Project Information:** Nomad Mobile Command Vehicle
- 2) **Primary Location:** 305 Butte Street, Yreka CA 96097
- 3) **Summary:** The response vehicle would allow the safe transport and use of the RAPIDHIT ID instrument to be deployed to scenes within our jurisdiction and respond to various crime scenes in rural areas. The response vehicle includes a generator, sample refrigerator, climate control, but we would need to add satellite, and remote communication capabilities. Eventually, our hope would be to assist neighboring agencies with requests for support.
Using a mobile command center for law enforcement offers many benefits. They provide a centralized location for communication and coordination. Officers at the scene can securely communicate with each other in real time. This promotes efficient decision making and quick response times, essential during critical incidents. Major incidents also generate enormous amounts of data, including information from surveillance cameras, drones, and radio traffic. A mobile command center offers the ability to receive, process, and share all this data on site. As a result, many law enforcement agencies are deploying them in small, and large-scale events.
- 4) **Project Funding and Costs:**
 - i. **Total Project Cost:** \$767,801.00
 - j. **Total Item Request:** \$783,157.00
 - a. (assumed 2% increase from time of original quote)
 - k. **If request is granted, will additional funding be necessary to complete the project?** Not for the initial purchase, general funds will support on-going maintenance for the life of the asset and a decal.
 - i. **What is the status on any current attempts to acquire additional funds?** None.
 - ii. **Can the project be started without these additional funds?** No.
 - l. **Has the project received funding from other sources?** No
 - i. **This should include Federal, State, local, non-profit, corporate, or any other entities which have provided funding.** No
 - m. **Why is this project a priority for California's 1st Congressional District?** Regarding critical incident response, we are confident this addition to our services would streamline processes with the public, analysis of collected samples, and increase turn around on critical information and save staff time which is saving taxpayer dollars in overtime pay.
 - n. **Why is this project a good use of taxpayer funds?** Mobile command centers fill a critical need in our line of work because requests from the public take us beyond the capabilities of brick and motor facilities. Our agency responds to trauma, loss of property and life, and provides essential services. A mobile command center would allow us to support the public in the most rural areas within Siskiyou County.
 - o. **Are you requesting this project from another Representative, or either of California's Senators?** No
 - p. **Do you have documentation showing community support for this project?** Yes, attached.

- i. Letters of support from elected officials. Yes, three are attached.
- ii. Articles in a local newspaper, including editorial boards. No.
- iii. Federal, State, or local plans identifying the project as needed – such as an infrastructure or community development plan. No.
- iv. Local resolutions passed in support of the project. No.

5) Supporting Documentation:



WHEN EVERY MINUTE MATTERS // NOMADGCS.COM + 888.755.1721

Nomad Global Communications Solutions, Inc. is pleased to provide you with the following budget quote for one (1) Nomad IC20As0 Mobile Command Vehicle to meet your requirements.

Item	Description	Quantity	Item Price	Total Price
1	Nomad IC20As0 Mobile Command Vehicle <ul style="list-style-type: none"> - Ford F-550 4x4 Regular Cab XLT Chassis - 20' Nomad Purpose Built Command Vehicle Shelter - Nomad Total Command (NTC) Safety, Training and Automation System - Super Single Off-Road Suspension Package - Custom Front Bumper w/ 12,000 lbs Warn Winch - Auto Leveling System - Underchassis Storage Package - Curbside Awning - Roof Access Ladder - Antenna Radio Rail - LED Exterior Scene and Emergency Lighting Package - 12KW Cummins Onan Generator - 50A Shore Power System - HVAC System - 40 ft Pneumatic Mast Package - Separated Command and Conference Areas - Storage Cabinets - Galley Area - LED Interior Lighting - 40U Data Rack Package - Silver A/V System Package - Silver Communications System Package - Nomad Standard 12-Year Workmanship Warranty - Delivery 365-420 Days ARO 	1	\$704,075.58	\$704,075.58
2	Delivery & Training	1	\$8,500.00	\$8,500.00
SUBTOTAL BEFORE OPTIONS				\$712,575.58

Technical Notes/Clarifications:

- Any purchases resulting from this quotation must reference this quotation or, in some other way, invoke the terms and conditions expressed in this quote.
- All pricing and specifications are proprietary and confidential to Nomad. No public distribution or dissemination is allowed without prior written permission from Nomad.
- Local and State sales taxes are not included in proposed pricing, unless otherwise required in the contract terms.
- 2% rebate is available for prepayment in full.
- All projects are subject to availability.
- All projects are subject to a payment schedule of 30/30/30/10, unless otherwise specified in the contract.
- All warranty terms are CONUS unless otherwise specified in the contract.
- The project must be paid in full upon final acceptance before keys and title can be transferred.
- Invoices are due on the receipt date. Finance charges will be added at a periodic rate of 1.5% per month applied to balances over 30 days old from the invoice date.
- All quotes are valid for the financial quarter in which this quote was received.
- 5% fee applies to credit card charges.

Thank you very much for your time and for considering Nomad for your Specialty Vehicle needs. The information that I have provided you is a small sample of the type of products and services that Nomad can provide. If you have any specific operational goals you need to meet that these specifications do not take into account, we would be pleased to work up some additional information for your review.

Please do not hesitate to call or email me if you have any questions or concerns. I look forward to hearing from you in the near future.

Sincerely,



Brandon Meadors
Vertical Sales Manager
Nomad Global Communication Solutions
Mobile: 406.885.8986
Office: 406.863.6167
Brandon.Meadors@nomadgcs.com

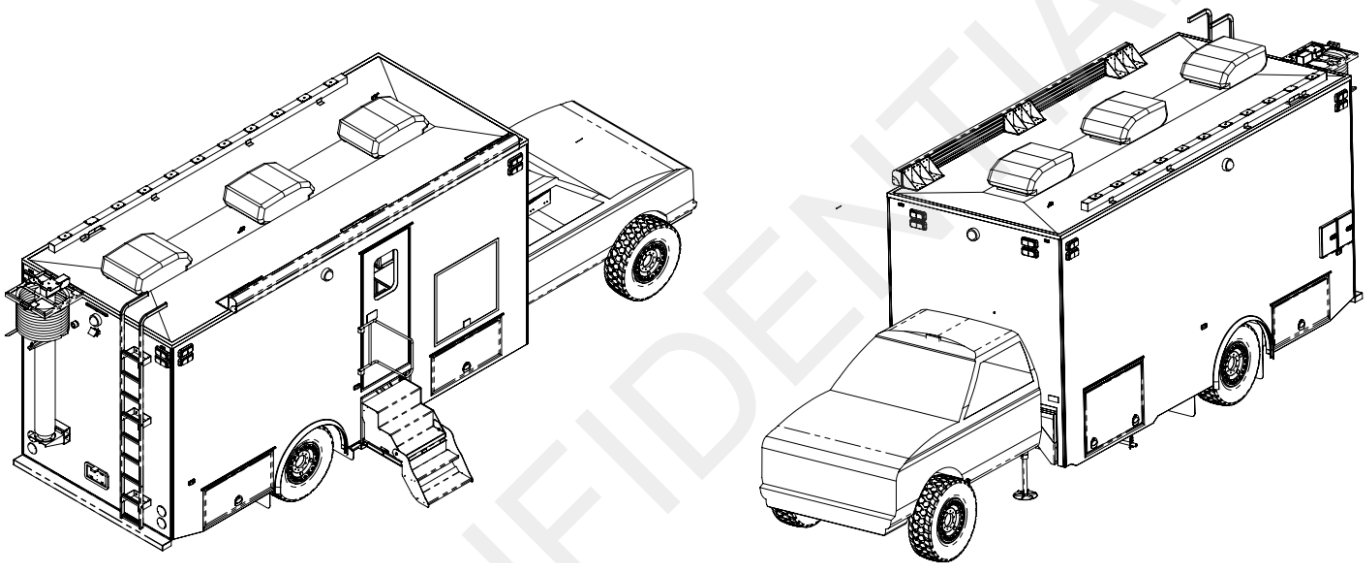

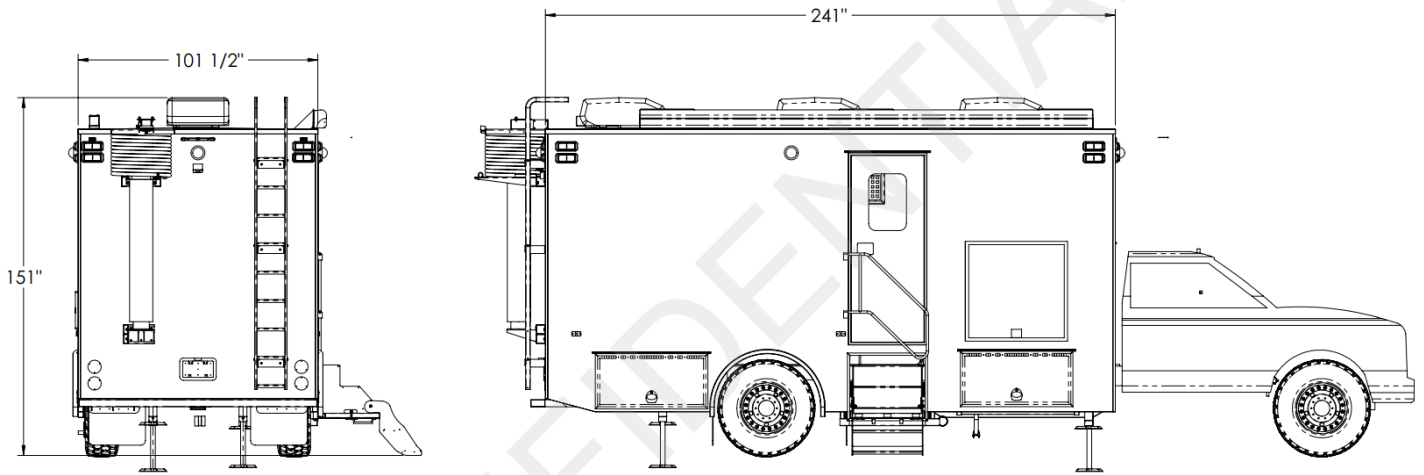

EXTERIOR

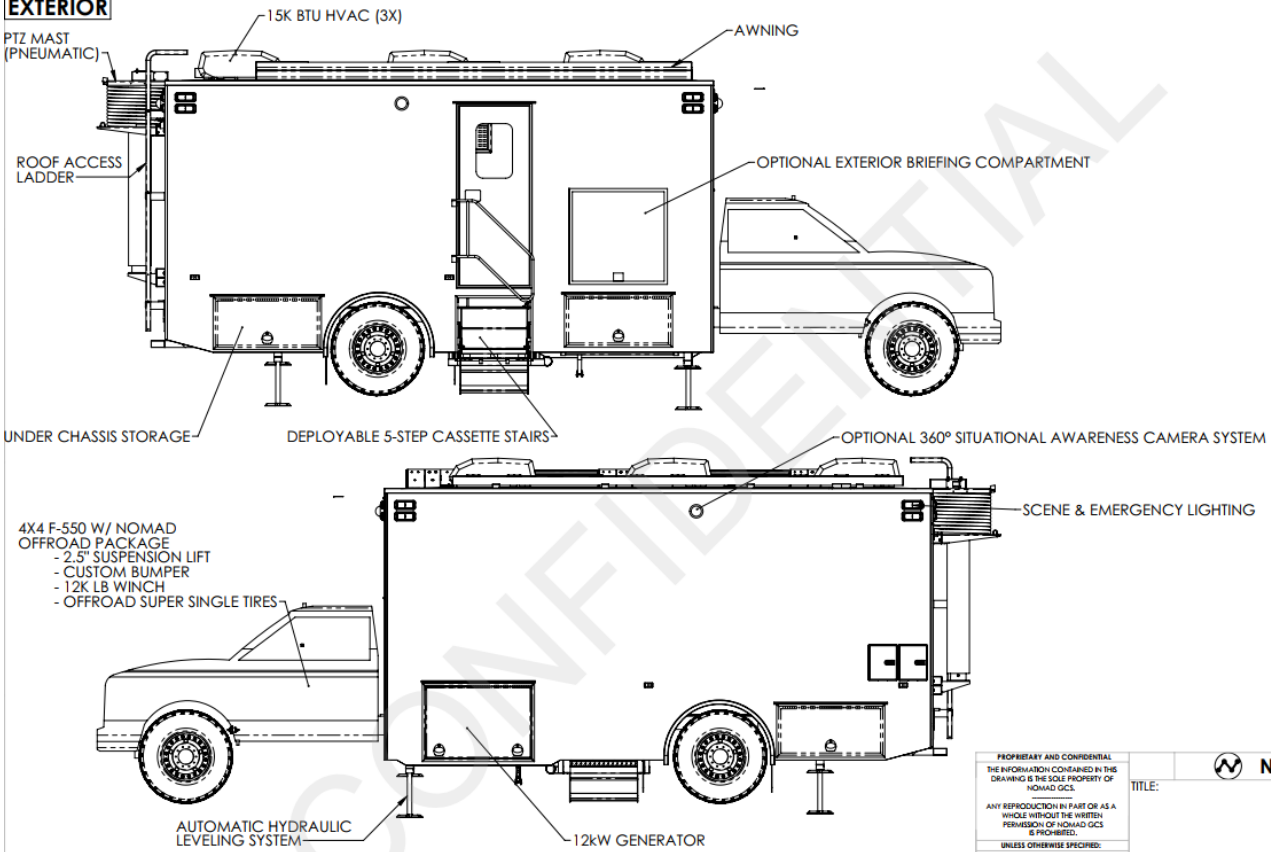

PRELIMINARY. FOR QUOTING PURPOSES ONLY.

PROPRIETARY AND CONFIDENTIAL
 THE INFORMATION CONTAINED IN THIS
 DRAWING IS THE SOLE PROPERTY OF
 NOMAD GCS.

ANY REPRODUCTION IN PART OR AS A
 WHOLE WITHOUT THE WRITTEN
 PERMISSION OF NOMAD GCS
 IS PROHIBITED.

UNLESS OTHERWISE SPECIFIED:
DIMENSIONS ARE IN INCHES
 TOLERANCES: X/X ± 1/16
 .X" ± 0.5"
 .X ± 0.100
 .XX ± 0.050
 .XXX ± 0.030

TITLE:	
DWG. NO.	REV.
Bid-804925	-
DO NOT SCALE DRAWING	SHEET 3 OF 4

INTERIOR

Drawings are for informational purposes only. If there is a discrepancy between the drawings and the Nomad specifications, the specifications will take precedence.

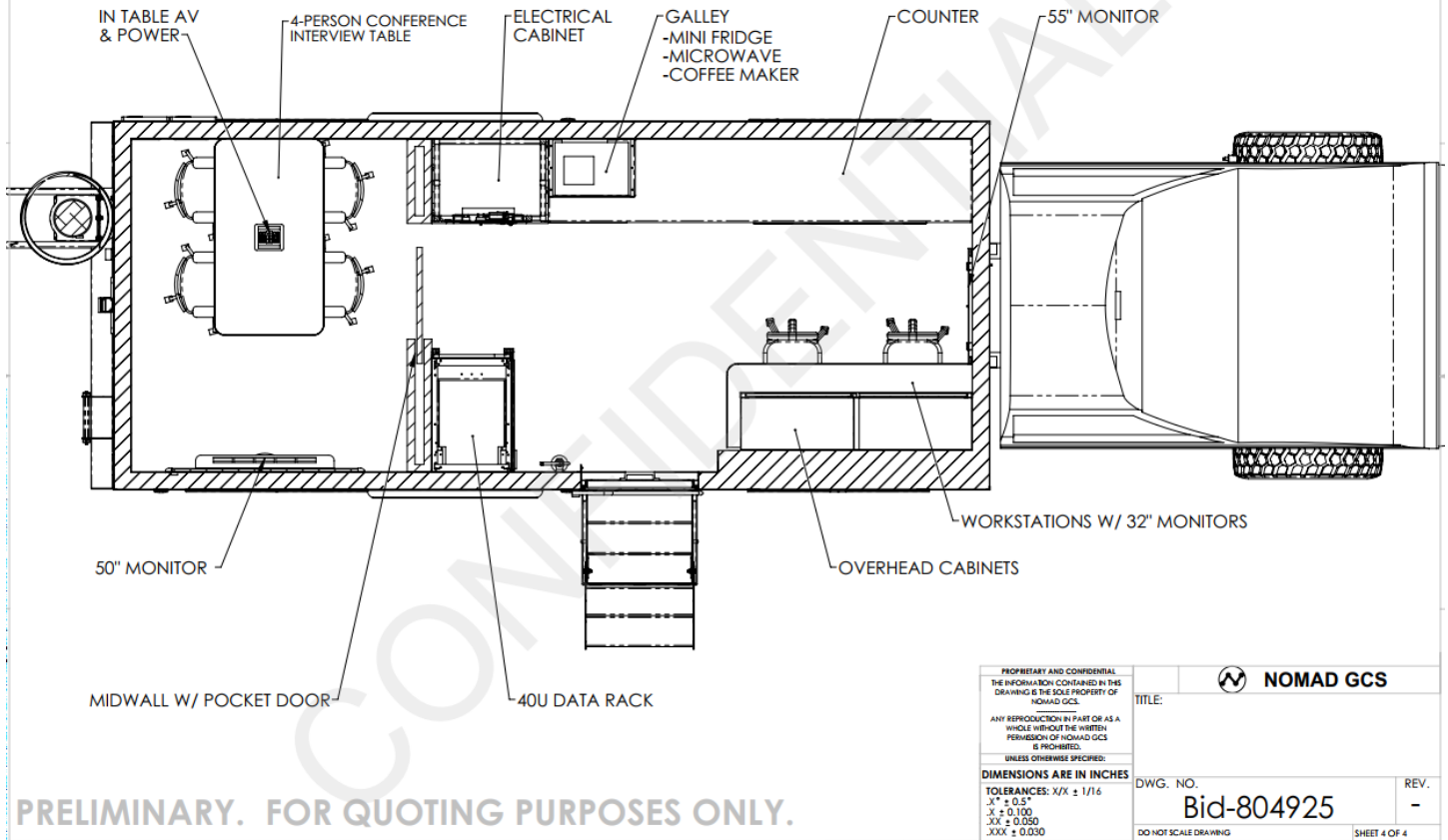

PRELIMINARY. FOR QUOTING PURPOSES ONLY.

<small>PROPRIETARY AND CONFIDENTIAL THE INFORMATION CONTAINED IN THIS DRAWING IS THE SOLE PROPERTY OF NOMAD GCS.</small> <small>ANY REPRODUCTION IN PART OR AS A WHOLE WITHOUT THE WRITTEN PERMISSION OF NOMAD GCS & PROHIBITED.</small> <small>UNLESS OTHERWISE SPECIFIED: DIMENSIONS ARE IN INCHES</small> <small>TOLERANCES: X/XX ± 1/16 X" ± 0.5" X' ± 0.100 .XX ± 0.030 .XXX ± 0.030</small>		
	TITLE:	
DWG. NO.	REV.	
Bid-804925		-
DO NOT SCALE DRAWING		SHEET 4 OF 4

NOMAD COST BREAKDOWN	
Quoted Cost	\$ 712,575.58
Tax @ 7.75%	\$ 55,224.61
Grand Total	\$ 767,801.00
2% Vendor Increase	\$ 14,251.51
Add'l Tax	\$ 1,104.49
Requested Amount:	\$ 783,157.00

Item #3: Supporting Lab Equipment – Mini Fridge, Laptop, Gloves, Radio

- 1) **Project Information:** Equipment – Nomad Vehicle and Crime Lab
- 2) **Primary Location:** 311 Lane Street, Yreka CA 96097
- 3) **Summary:** These additional supplies and, or equipment would be highly beneficial to maintaining the integrity of collected samples, assist with electronic fact gathering, assist with organizing data in the field and provide required PPE to agency staff. The radio requested will be installed within the Nomad vehicle to keep our staff in communication with dispatch and other first responding teams.
- 4) **Project Funding and Costs:**

- a. **Total Project Cost:** \$12,990.00
- b. **Total Item Request:** \$13,512.00
- q. **If request is granted, will additional funding be necessary to complete the project?** No.
 - i. **What is the status on any current attempts to acquire additional funds?** None.
 - ii. **Can the project be started without these additional funds?** Not that we can confidently identify.
- r. **Has the project received funding from other sources?** No.
 - i. **This should include Federal, State, local, non-profit, corporate, or any other entities which have provided funding.** No.
- s. **Why is this project a priority for California's 1st Congressional District?**
 - i. The ability to store evidence to compliancy standards maintains integrity of the sample which provides more accurate results regarding cases involving convictions and decedent identification.
 - ii. The fridge would be in our crime lab area for short term storage. Gloves are essential PPE for forensic staff. Not only does it assist avoiding contamination of the samples collected, but it also provides staff with safety measures for bodily fluids or chemicals encountered.
 - iii. The radio requested would be installed in the Nomad vehicle to preserve vital communication with law enforcement and dispatch considering our forensic team is not sworn. Whether they are working on or off the primary site, we want them to have the most current knowledge of any changes to their surroundings.
- t. **Why is this project a good use of taxpayer funds?** We are confident these items will either increase situational safety or reduce the margin of error in any data presented to the public and, or the Courts.
- u. **Are you requesting this project from another Representative, or either of California's Senators?** No
- v. **Do you have documentation showing community support for this project?** Yes, attached.
 - i. **Letters of support from elected officials.** Yes, three are attached.
 - ii. **Articles in a local newspaper, including editorial boards.** No.
 - iii. **Federal, State, or local plans identifying the project as needed – such as an infrastructure or community development plan.** No.
 - iv. **Local resolutions passed in support of the project.** No.

Supporting Documentation:

Mini Fridge Quote:



100+ bought since yesterday

Best seller **Rollback**

Galanz
Galanz 4.6 Cu ft Two Door Mini Refrigerator with Freezer, Stainless Steel, New, Width 19.13"

★★★★★ (4.3) 2288 reviews

Now \$188.00 ~~\$269.99~~

You save \$81.99

\$18/mo with **affirm** [Learn how](#)
Price when purchased online

Add a protection plan [What's covered](#)
(Only one option can be selected at a time)

2-Year plan - \$18.00

3-Year plan - \$24.00

How you'll get this item:

I want shipping & delivery savings with **Walmart+**
You get 30 days free! Choose a plan at checkout.

MINI FRIDGE COST BREAKDOWN

Anticipated Cost \$ 188.00
 Tax @ 7.75% \$ 14.57
Requested Amount: \$ 203.00

Most Recent Vendor Quote (Radio):

MOTOROLA SOLUTIONS QUOTE-2482422
 (2)_APX8500

Billing Address: SISKIYOU COUNTY
 305 BUTTE ST
 YREKA, CA 96097
 US

Shipping Address: SISKIYOU COUNTY
 305 BUTTE ST
 YREKA, CA 96097
 US

Quote Date: 01/09/2024
 Expiration Date: 03/09/2024
 Quote Created By: Matthew Weinberger
 Wireless System Sales
 mweinberger@daywireless.com
 (530) 440-9030

End Customer: SISKIYOU COUNTY
 Courtney Greenley
 cgreenley@co.siskiyou.ca.us
 (530) 842-8326

Delivery Address: SISKIYOU COUNTY
 279 SHARPS LN
 YREKA, CA 96097
 US

Contract: 36273 - SOURCEWELL
 042021-MOT

MOTOROLA SOLUTIONS QUOTE-2482422
 (2)_APX8500

Line #	Item Number	Description	Qty	List Price	Disc %	Sale Price	Ext. Sale Price
1h	G843AH	ADD: AES ENCRYPTION AND ADP	2				
1i	G444AH	ADD: APX CONTROL HEAD SOFTWARE	2				
1j	GA01517AA	DEL: NO J600 ADAPTER CABLE NEEDED	2				
1k	G806BL	ENH: ASTRO DIGITAL CAI OP APX	2				
1l	GA01670AA	ADD: APX E5 CONTROL HEAD	2				
1m	W969BG	ADD: MULTIKEY OPERATION	2				
1n	W22BA	ADD: STD PALM MICROPHONE APX	2				
1o	QA09113AB	ADD: BASELINE RELEASE SW	2				
Subtotal							\$14,854.94
Estimated Tax							\$1,151.26
Grand Total							\$16,006.20(USD)

Line #	Item Number	Description	Qty	List Price	Disc %	Sale Price	Ext. Sale Price
APX™ 8500							
1	M377XS9PW1AN	APX8500 ALL BAND HP MOBILE	2	\$9,997.08	25.7%	\$7,427.47	\$14,854.94
1a	GA00318AF	ENH: 5 YEAR ESSENTIAL SVC	2				
1b	G831AD	ADD: SPKR 15W WATER RESISTANT	2				
1c	G48BB	ENH: CONVENTIONAL OPERATION APX	2				
1d	GA01513AB	ADD: ALL BAND MOBILE ANTENNA (7/8A/U)	2				
1e	GA05507AA	DEL: DELETE 7/800MHZ BAND	2				
1f	GA01606AA	ADD: NO BLUETOOTH/ WIFI/GPS ANTENNA NEEDED	2				
1g	W12DK	ADD: RF PREAMP APX	2				

RADIO COST BREAKDOWN

Quoted Cost \$ 8,003.10
 5% Vendor Increase \$ 400.16
 Add'l Tax \$ 31.01
Requested Amount: \$ 8,435.00

Laptop Quote (Dell):



Your quote is ready for purchase.

Complete the purchase of your personalized quote through our secure online checkout before the quote expires on **May. 17, 2024**.

You can download a copy of this quote during checkout.

[Place your order](#)

Quote Name:	Sheriff -15" Forensic Laptop Standalone	Sales Rep	Jordan Gibbs
Quote No.	3000174813501.4	Phone	(800) 456-3355, 6179306
Total	\$1,782.34	Email	Jordan_Gibbs@Dell.com
Customer #	4506164	Billing To	ACCOUNT PAYABLE COUNTY OF SISKIYOU 311 4TH ST RM 102 YREKA, CA 96097- 2947
Quoted On	Apr. 17, 2024		
Expires by	May. 17, 2024		
Contract Name	Dell NASPO Computer Equipment PA - California		
Contract Code	C000001115143		
Customer Agreement #	23026 / 7-23-70-55-01		
Deal ID	26964903		

Message from your Sales Rep

Please use the Order button to securely place the order with your preferred payment method online. You may contact your Dell sales team if you have any questions. Thank you for shopping with Dell.

Regards,
Jordan Gibbs

Product	Unit Price	Quantity	Subtotal
Dell EcoLoop Essential Backpack 14-16	\$27.74	1	\$27.74
Dell Latitude 5540	\$1,608.91	1	\$1,608.91
C2G 7.5in USB 2.0 to Ethernet Adapter - Network adapter - USB 2.0 - 10/100 Ethernet - silver	\$34.01	1	\$34.01
Subtotal:			\$1,670.66
Shipping:			\$0.00
Environmental Fee:			\$5.00
Non-Taxable Amount:			\$299.27
Taxable Amount:			\$1,376.39
Estimated Tax:			\$106.68
Total:			\$1,782.34

LAPTOP COST BREAKDOWN

Quoted Cost	\$	1,783.00
2% Vendor Increase	\$	83.53
Add'l Tax	\$	6.47
Requested Amount:	\$	1,874.00

GLOVES COST BREAKDOWN

Anticipated 3-Year Cost	\$	3,000.00
Requested Amount:	\$	3,000.00

Item #4: Communication Services – STARLINK

- 1) Project Information:** Starlink Satellite Services
- 2) Primary Location:** 305 Butte Street, Yreka CA 96097
- 3) Summary:** Starlink satellite services allow for connections in the most remote places. Due to the rural and mountainous nature of our County, we consistently find dead zones even with multiple providers such as T-Mobile, SATCOM and Verizon. We have received positive feedback from other agencies utilizing this service and feel it would be extremely beneficial to add to the Nomad Vehicle. The package we have selected is configured for emergency

response teams specifically. This service is billed monthly and charged to a County issued cal card until cancelled. We are asking for a 3-year term knowing this award may fund a project up to 36 months. Our County CFO has already approved us to use a cal card for this service and reimbursement.

4) Project Funding and Costs:

- a. **Total Project Cost:** \$9,646.00
- b. **Total Item Request:** \$9,646.00
- c. **If request is granted, will additional funding be necessary to complete the project?** No.
 - i. **What is the status on any current attempts to acquire additional funds?** None.
 - ii. **Can the project be started without these additional funds?** No.
- d. **Has the project received funding from other sources?** No.
 - i. **This should include Federal, State, local, non-profit, corporate, or any other entities which have provided funding.** No.
- e. **Why is this project a priority for California's 1st Congressional District?** One of the purposes of a mobile office is reducing the need to drive back and forth between the scene and the office. In our County, a round trip could occupy an entire scheduled shift. We feel having this service would allow us to remain in an off-site location for any duration of time without causing a disruption to urgent timelines or public service.
- f. **Why is this project a good use of taxpayer funds?** The public has a high expectation of service from public safety agencies and without reliable internet or mobile services, it would be less efficient of time which would be underutilizing taxpayer funding.
- g. **Are you requesting this project from another Representative, or either of California's Senators?** No
- h. **Do you have documentation showing community support for this project?** Yes, attached.
 - i. **Letters of support from elected officials.** Yes, three are attached.
 - ii. **Articles in a local newspaper, including editorial boards.** No.
 - iii. **Federal, State, or local plans identifying the project as needed – such as an infrastructure or community development plan.** No.
 - iv. **Local resolutions passed in support of the project.** No.

5) Supporting Documentation:

<https://www.starlink.com/>

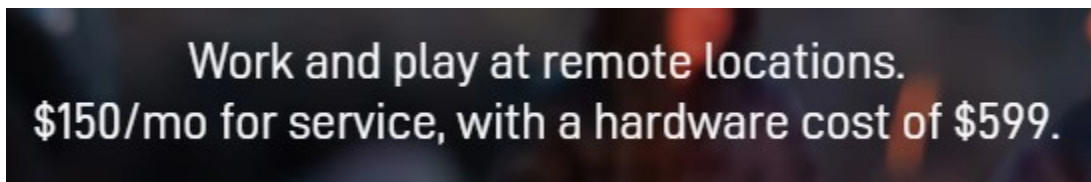

Best for maritime, emergency response, and mobile businesses

KEY FEATURES

All The Features of Mobile - Global Service

In-motion + Ocean Use

Network Priority

Priority Support

MONTHLY SERVICE PLANS

UNLIMITED MOBILE GLOBAL DATA INLAND

+

MOBILE PRIORITY - 50GB **\$250**/MO

STARLINK COST BREAKDOWN	
Startup Supplies	\$ 599.00
Tax @ 7.75%	\$ 46.42
3 Year Service Plan	\$ 9,000.00
Requested Amount:	\$ 9,646.00

Item #5: BODE Contract – DNA Testing Services

- 1) **Project Information:** BODE Technology Contract for DNA Services
- 2) **Primary Location:** 305 Butte Street, Yreka CA 96097
- 3) **Summary:** Bode’s Rapid DNA Services offer a variety of solutions to support the investigation beyond obtaining data, from validating the instruments and training the users to providing ongoing, real-time reachback support. Bode’s BodeHITS™ local databasing solution is the perfect complement to Rapid DNA. Their accredited laboratory and trained DNA analysts handle evidence with complex DNA mixtures and compare them to rapid DNA profiles. Bode’s Rapid DNA Services provide DNA database solutions that meet published quality standards and expedited results in investigations through identifying individuals, supplying investigative leads, and exonerating suspects in criminal investigations. The package includes the validation of the Rapid Hit ID instrument, a year access of their reach back program which is used for any sample that does not fully pass the instruments initial run, and access to the local database software where all profiles that are ran through the instrument and sent to the lab for testing are stored and searched against each other. Any profile match tested locally would result in an immediate notification to the booking, arresting, and investigating agency so law enforcement can review while an arrestee is still in custody, possibly preventing additional crimes.
- 4) **Project Funding and Costs:**
 - a. **Total Project Cost:** \$94,340.00
 - b. **Total Item Request:** \$94,340.00

- c.If request is granted, will additional funding be necessary to complete the project? No.
 - i.What is the status on any current attempts to acquire additional funds? None.
 - ii.Can the project be started without these additional funds? No.
- d.Has the project received funding from other sources? No.
 - i. This should include Federal, State, local, non-profit, corporate, or any other entities which have provided funding. No.
- e. Why is this project a priority for California’s 1st Congressional District? It would reduce the turn around time on criminal and property crimes by allowing us to cross reference a local database before utilizing CODIS. Sending DNA to a DOJ lab is not as time efficient.
- f. Why is this project a good use of taxpayer funds? It would enhance public safety, especially to those in the Yreka area where the Jail is located. If we can provide immediate evidence of a crime committed, we may not be releasing someone who was in violation.
- g.Are you requesting this project from another Representative, or either of California’s Senators? No
- h.Do you have documentation showing community support for this project? Yes, attached.
 - i.Letters of support from elected officials. Yes, three are attached.
 - ii.Articles in a local newspaper, including editorial boards. No.
 - iii.Federal, State, or local plans identifying the project as needed – such as an infrastructure or community development plan. No.
 - iv.Local resolutions passed in support of the project. No.

5) Supporting Documentation:

<https://bodetech.com/validation-consulting/forensic-research-and-support-operations/>



BodeHITS and Rapid DNA – Pricing
 Siskiyou County Sheriff's Department
 February 1, 2024
 Quote 0224-001V1

Terms and Conditions

The pricing and scope of work attached is valid until **April 1, 2024** unless entered into a contract.

Terms of payment are Net-30 directly billed to the Client. All testing at Bode is subject to our [Terms and Conditions](#).

BodeHITS and Rapid DNA Support Packages

BodeHITS – Bundled Packages

SKU	Item Name	Description	Price
H19P02	Package 1: DNA Database and Rapid Support Package	Rapid instrument validation and ongoing support (H19S03) <ul style="list-style-type: none"> • Validation services and ongoing quality checks of the client instrument as described below (not applicable to Intel Plus) 	\$28,500 per year
Includes: - H19S01 - H19S03 - H19S05		BodeHITS Annual Subscription (H19S01) <ul style="list-style-type: none"> • Access to program to develop a DNA database. This program includes the ability to search against other in-state DNA databases as described below On-demand Rapid DNA Reachback Support (H19S05) <ul style="list-style-type: none"> • On-demand support from qualified forensic DNA analysts to review flagged Rapid DNA samples as described below 	

BODE COST BREAKDOWN

Quoted Cost - Yr 1	\$	29,925.00
Anticipated Cost - Yr 2	\$	31,421.25
Anticipated Cost - Yr 3	\$	32,993.00
Requested Amount:	\$	94,339.25



Answers for local cases.

Local crimes require local solutions. Quickly identifying and eliminating suspects is critical in ensuring rapid resolution of cases. Building, growing, and utilizing a local DNA database will lead to a decrease in crime and provide a solution that delivers for years to come.

SOLVE PROPERTY & GUN CRIMES

Powered by Bode's fully accredited laboratory services and DNA-free collection products, BodeHITS allows law enforcement agencies to maintain control over which samples are submitted, and allows participation in expanded search opportunities.

- Quickly generate new investigative leads
- Fully compatible with Rapid DNA
- Instantly receive HITS directly from your database
- Search against other local agencies
- Expert witness testimony by qualified DNA analysts



BodeHITS 30 day turnaround time provides faster investigative leads.

BODE TECHNOLOGY **Answers with Confidence and Accuracy**
866-263-3443 or 703-646-9740 ■ bode.service@bodetech.com ■ bodetech.com